

MITSUBISHI ELECTRIC AUTOMATION, INC.

UNINTERRUPTIBLE POWER SUPPLY SYSTEM

2033C SERIES

OWNERS / TECHNICAL MANUAL

Preface

TABLE OF CONTENTS

LIST OF TABLES	iii
LIST OF FIGURES	iv
HOW TO USE THIS MANUAL	v
1.0 INTRODUCTION	1-1
1.1 GENERAL.....	1-3
1.2 DEFINITIONS	1-4
1.3 OVERVIEW	1-5
1.4 SPECIFICATIONS	1-14
2.0 OPERATION CONTROLS AND INDICATORS	2-1
2.1 LCD TOUCH PANEL MONITOR DISPLAY AND KEYPAD	2-1
2.2 EXTERNAL SIGNAL TERMINAL BLOCK	2-5
2.3 EXTERNAL COMMUNICATION CONNECTOR	2-8
3.0 INSTALLATION AND OPERATION	3-1
3.1 TRANSPORTATION AND INSTALLATION	3-1
3.2 HANDLING	3-1
3.3 INSTALLATION PROCEDURE	3-2
3.4 PROCEDURE FOR CABLE CONNECTIONS	3-3
3.5 OPERATING PROCEDURES	3-9
3.6 MAINTENANCE BYPASS SET-UP PROCEDURES	3-10
4.0 RESPONSE TO UPS FAILURE	4-1
5.0 PARTS REPLACEMENT	5-1
6.0 FAULT CODES	6-1
7.0 WARRANTY & OUT OF WARRANTY SERVICE	7-1

List of Tables

Table 1.1	Power Specifications	1-14
Table 1.2	UPS Module Information.....	1-14
Table 1.3	Detail of Specifications	1-15
Table 1.4	Rating of Conductor and Fuses	1-16
Table 3.1	How to Transport and Install the System	3-1
Table 3.2	List of UPS Weights (lb.).....	3-2
Table 3.3	Type and Number of Internal Battery	3-2
Table 3.4	Recommended Cable Size and Torque Requirements	3-4
Table 3.5	Crimp Type Compression Lug	3-4

List of Figures

Figure 1.1	Single Line Diagram-Normal Operation	1-5
Figure 1.2	Single Line Diagram-Bypass Operation.....	1-6
Figure 1.3	Single Line Diagram-Battery Operation	1-7
Figure 1.4	Single Line Diagram - UPS on Maintenance Bypass Operation..	1-7
Figure 1.5a	UPS Parts Location (7.5-20kVA)	1-9
Figure 1.5b	UPS Parts Location (30kVA)	1-10
Figure 1.5c	UPS Parts Location (40,50kVA)	1-11
Figure 1.6	Display PCB DPAU-72	1-11
Figure 1.7	External I/F PCB RYDR-X	1-11
Figure 1.8	Main Control PCB UPFR-K.....	1-12
Figure 2.1	Operation/Display Panel	2-1
Figure 2.2	MAIN MENU Screen	2-2
Figure 2.3	MEASUREMENT Screens	2-2
Figure 2.4	DATE&CLOCK SETUP Screen	2-4
Figure 2.5	External Signal Terminal Block	2-5
Figure 2.6	External Signal Terminal Block	2-5
Figure 2.7	Control Wiring for External Contacts	2-6
Figure 2.8	Remote "Start" Contact Connections.....	2-7
Figure 2.9	External communication connector.....	2-8
Figure 3.1	Handling	3-1
Figure 3.2	UPS Terminal Designation	3-5
Figure 3.3	Input / Output Power Terminals (7.5-20kVA) -.....	3-6
Figure 3.4	Input / Output Power Terminals (30kVA)	3-7
Figure 3.5	Input / Output Power Terminals (40,50kVA)	3-8
Figure 3.6	EPO Button	3-9

How to use this Manual

This manual is designed for ease of use, giving the user easy and quick reference to information. This manual uses notice icons to draw attention to the user important information regarding the safe operation and installation of the UPS. The notice icons used in this manual are explained below, and should be taken into account and adhered to whenever they appear in the text of this manual.



Warning: A warning notice icon conveys information provided to protect the user and service personnel against hazards and/or possible equipment damage.



Caution: A caution notice icon conveys information provided to protect the user and service personnel against possible equipment damage.



Note: A Note notice icon indicates when the user should make a reference of information regarding the UPS operation, load status and display status. Such information is essential if Mitsubishi field service group assistance and correspondence is required.

Safety Recommendations: If any problems are encountered while following this manual, Mitsubishi field service group assistance and correspondence is recommended.

1.0 INTRODUCTION

The Mitsubishi Uninterruptible Power Supply (UPS) is designed to provide many years of reliable power supply and protection from power failure, brown-outs, line noise and voltage transients. To ensure optimum performance of the equipment, follow the manufacturer's instructions accordingly. This manual contains descriptions for the installation and operation procedures of the UPS. Please read this manual carefully and retain it for future reference.

**IMPORTANT SAFETY INSTRUCTIONS
RETAIN THESE INSTRUCTIONS**



This manual contains important instructions for the 2033C Series Uninterruptible Power Supply Systems that should be adhered to during installation, operation and maintenance of the UPS and batteries.

WARNING 1



**Lethal voltages exist within the equipment during operation.
Observe all warning and cautions in this manual.
Failure to comply may result in serious injury or death.
Obtain a qualified service for this equipment as per instructions.**

WARNING 2

This UPS does not include an AC input circuit breaker (MCCB) to protect the bypass and main input circuit. The AC input circuit breaker (MCCB) is to be field supplied and installed. Circuit breaker (MCCB) specifications are as follows:

Capacity (kVA)	AC input Voltage (Vac)	AC input Rating (Aac)	Recommended Breaker (A)
7.5	208	23	30
10	208	30	35
15	208	45	60
20	208	61	75
30	208	91	125
40	208	121	150
50	208	151	200

AC output and DC input overcurrent protection and disconnection devices shall be field supplied and installed.

1.1 GENERAL

The Mitsubishi 2033C Series UPS is designed to provide continuous and clean electrical power to a critical load. In the event of an input power failure, the UPS will supply power to the critical load for the specified battery time.

If the input power is not restored promptly, backup power from the UPS battery permits the orderly shutdown of equipment supported by the UPS. The UPS is simple to start up, operate and maintain.

The 2033C Series UPS is available in seven (7) kVA sizes: 7.5, 10, 15, 20, 30, 40 and 50kVA. Specifications for each kVA model appear in Section 1.4. Models up to 30kVA have batteries included in the UPS module cabinet. 40kVA and 50kVA models have external batteries. The principles of operation described herein are applicable to all models.

This manual provides an overview of the 2033C Series components and their functions. The appearance and purpose of operator controls and indicators is described with procedures for operation, start-up, shutdown and basic maintenance included.

1.2 Definitions

UNINTERRUPTIBLE POWER SUPPLY SYSTEM (UPS) - All components within the UPS Module Cabinet and associated batteries which function as a system to provide continuous, conditioned AC power to a load. This is sometimes referred to as the "System".

UPS MODULE CABINET - The metal enclosure which contains the Converter / Charger, Inverter, Static Transfer Switch, Internal Bypass line, operator controls, batteries (up to 30kVA models only) and internal control systems required to provide specified AC power to a load.

UPS MODULE - The Converter / Charger and Inverter assemblies which, under the direction of the internal control system and operator controls, provide specified AC power to a load.

CONVERTER / CHARGER - The UPS components which contain the equipment and controls necessary to convert input AC power to regulated DC power required for battery charging and for supplying power to the Inverter.

INVERTER - The UPS components which contain the equipment and controls necessary to convert DC power from the Converter / Charger, or the battery, to AC power required by the critical load.

STATIC TRANSFER SWITCH - The device which connects the critical load to the bypass line when the Inverter cannot supply continuous power.

BYPASS LINE - The line which conducts electricity directly from the input power source to the critical load during Maintenance or whenever the UPS is not completely operational.

AC INPUT POWER - Power provided by the electrical utility company, or auxiliary generator, which is connected to the UPS for supplying the critical load and recharging the battery.

BATTERY - The rechargeable battery strings which supply DC power to the inverter to maintain continuous AC power to the load during AC input power failure conditions.

1.3 Overview

The UPS provides two power paths between the utility source and the critical load. Figure 1.1 shows the path for normal operation, with the load powered from the inverter. Figure 1.2 shows the path for bypass operation, with the load supplied through the static bypass line.

FIGURE 1.1 Single Line Diagram - Normal Operation. Load powered by inverter.

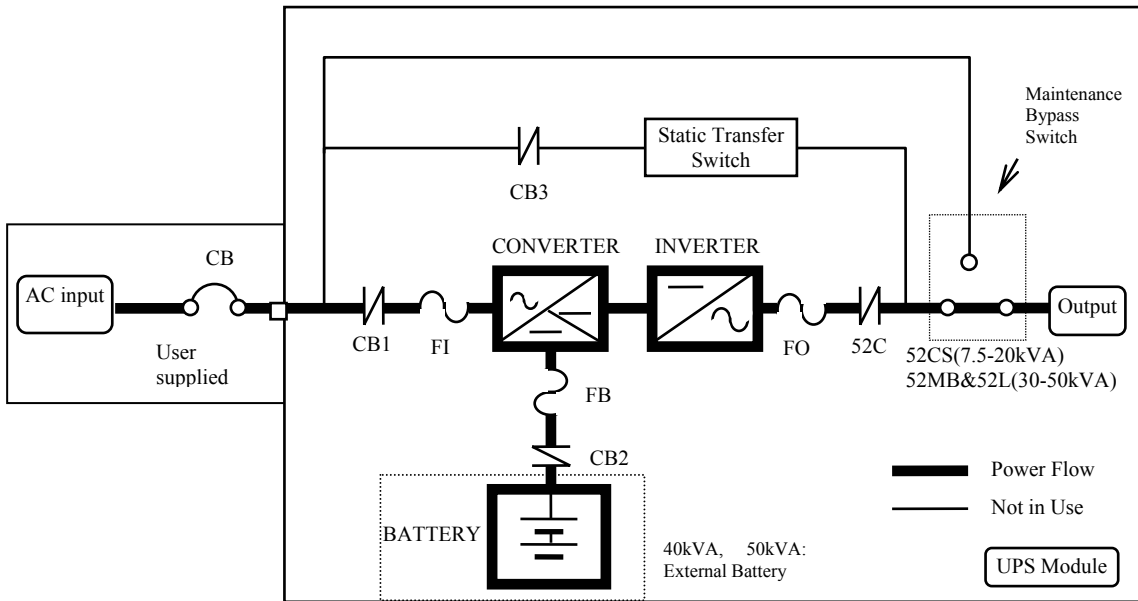

During normal operation, the path through the inverter is used to power the load.

Referring to Figure 1.1: Input AC power is converted to DC by the Converter. DC power is utilized to charge the UPS battery and to provide power to the Inverter. The Inverter converts the DC power to clean AC power to supply the critical load.

The conversion - inversion process eliminates any voltage transients or fluctuations existing in the input power before it reaches the critical load.



** The Input circuit breaker(MCCB) for protection of the UPS and cables are field supplied and field installed. (See WARNING 2 in section 1.0).*

FIGURE 1.2 Single Line Diagram - Bypass Operation. Load fed through static bypass line.

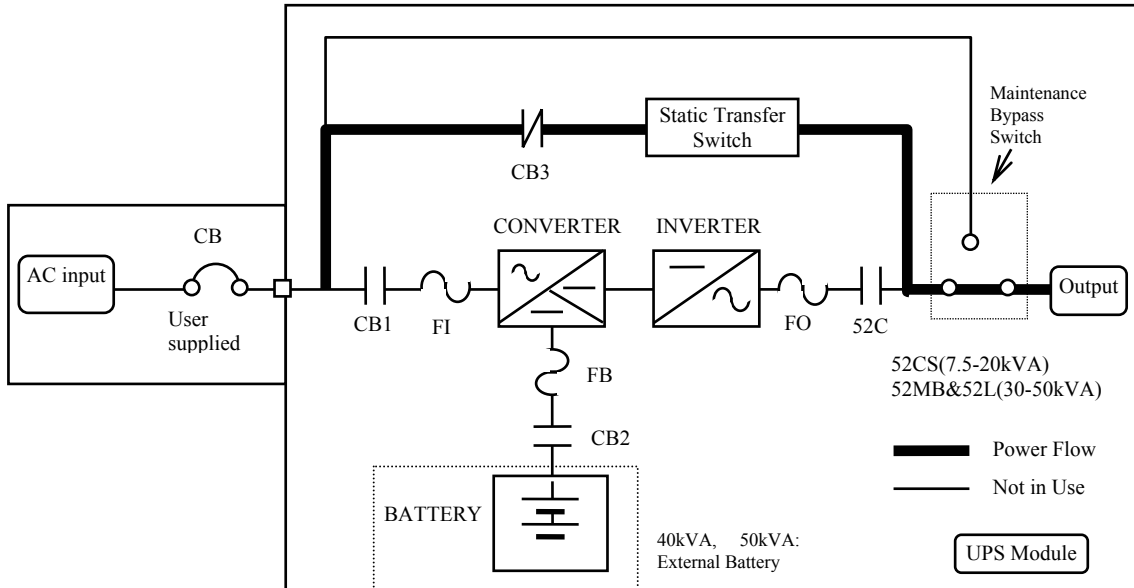

Referring to Figure 1.2, the Internal Static Bypass line is a Hard wired line through CB3 which supplies the critical load with unconditioned input power. The purpose of this line is to route power to the critical load while the UPS module is de-energized (converter and inverter), and during Start-up before the system is fully operational.

The internal control system determines the operation of the two paths, with the load powered from the inverter being the normal operation.

Referring to Figure 1.3, if the input power is interrupted, the battery will immediately supply the DC power required by the Inverter to maintain continuous AC power to the load. A fully charged battery will provide power for the specified time at the rated load, or longer at reduced load.

When power is restored after a low battery shutdown, the Converter automatically restarts operation, recharges the batteries and the Inverter is automatically restarted without operator intervention. The load is assumed by the inverter automatically without operator intervention.

In the event of a power failure, the Converter will de-energize and the batteries will discharge into the Inverter and maintain power to the critical load until a) the battery capacity expires and the inverter turns off, or b) input power is restored after which the converter will power the inverter and simultaneously recharge the batteries. Figure 1.3 illustrates the flow diagram during battery operation.

FIGURE 1.3 Single Line Diagram - Battery Operation

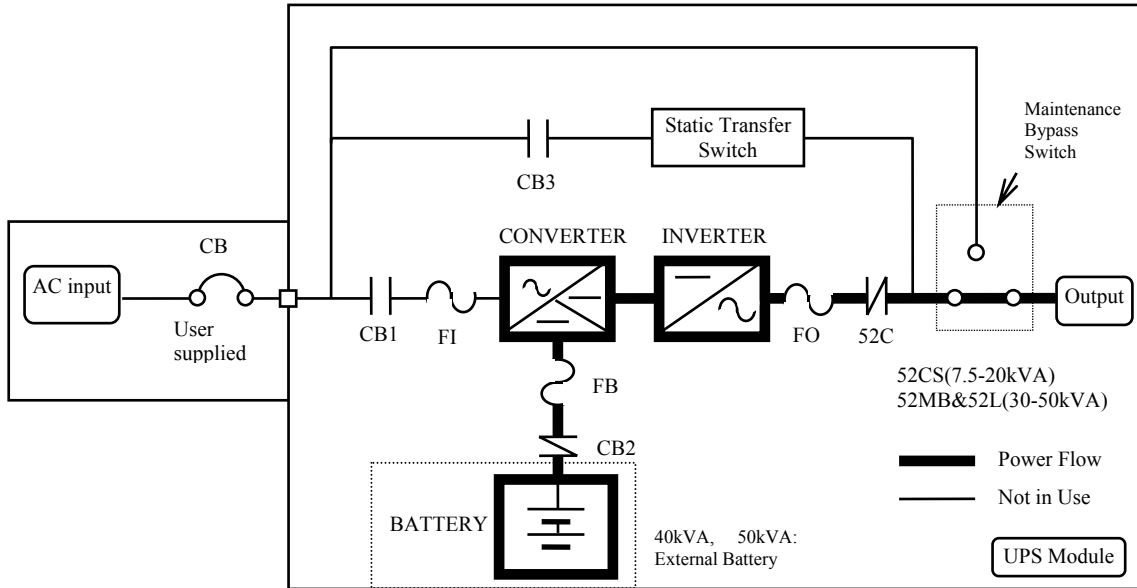

The UPS is equipped with an internal rotary type Maintenance Bypass Switch (MBS) that can be used to divert utility power to the load during maintenance sessions. Figure 1.4 illustrates the power path when the MBS is in the BYPASS mode.

FIGURE 1.4 Single Line Diagram - UPS on Maintenance Bypass Operation.

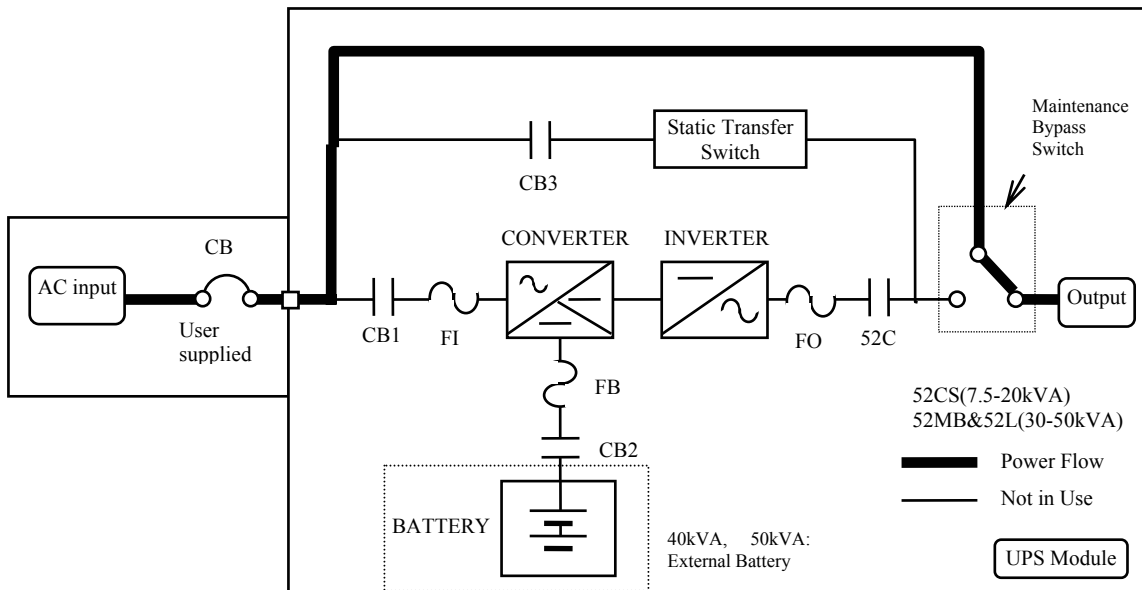

(7.5/10/15/20kVA)

The rotary maintenance bypass switch is shown as 52CS in Figure 1.4. 52CS is a two position three point make-before-break transfer switch.

(30/40/50kVA)

Two contactors (52MB, 52L) are used instead of the 52CS. A rotary switch(SWM) is used for control of the two contactors.

The two positions are identified as NORMAL and BYPASS. In the NORMAL position the load is fed by the UPS - either through the inverter or through the static bypass line. In the BYPASS position the load is powered by an external source such as the utility or a generator. This transfer operation must be made while the UPS is in the static bypass mode.

The transfer procedure to place the UPS in maintenance bypass mode, or from bypass mode to normal operation mode is outlined below:

A) Transfer of load from inverter to maintenance bypass

1. On the front panel, press the "STOP" button. The "BYP.OP." LED illuminates within 3 seconds.
2. After confirming that the "BYP.OP." LED is illuminated, Rotate MBS(52CS/SWM) clockwise to the "TRANSFER" position (Do not rotate 52CS/SWM if the "BYP.OP." LED is NOT illuminated).
3. After 3 seconds, rotate 52CS/SWM clockwise to the "BYPASS" position.
4. Transfer complete. Load is now powered from the external source. UPS can be shutdown.

B) Transfer of load from maintenance bypass to inverter

1. Rotate 52CS/SWM counterclockwise from the "BYPASS" position to the "TRANSFER" position, wait 5 seconds.
2. On the UPS, confirm the "BYP.OP." LED is illuminated. If not, press the "STOP" button.
3. Rotate 52CS/SWM counterclockwise to the "NORMAL" position.
4. On the UPS, press the "START" button. The "INV.OP." LED should illuminate.
5. Transfer complete. Load now powered by the inverter.

FIGURE 1.5a UPS Parts Location(7.5-20kVA)

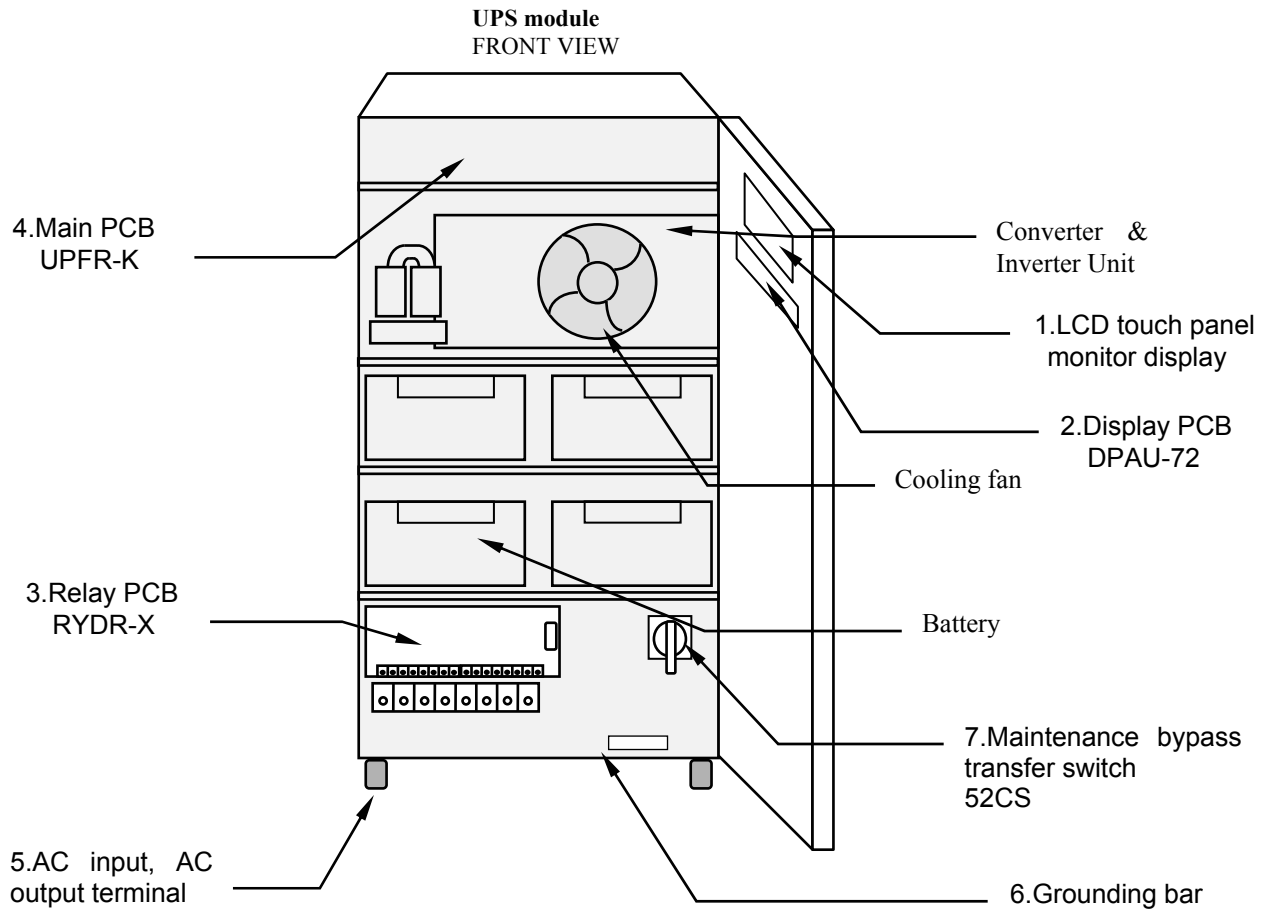

FIGURE 1.5b UPS Parts Location(30kVA)

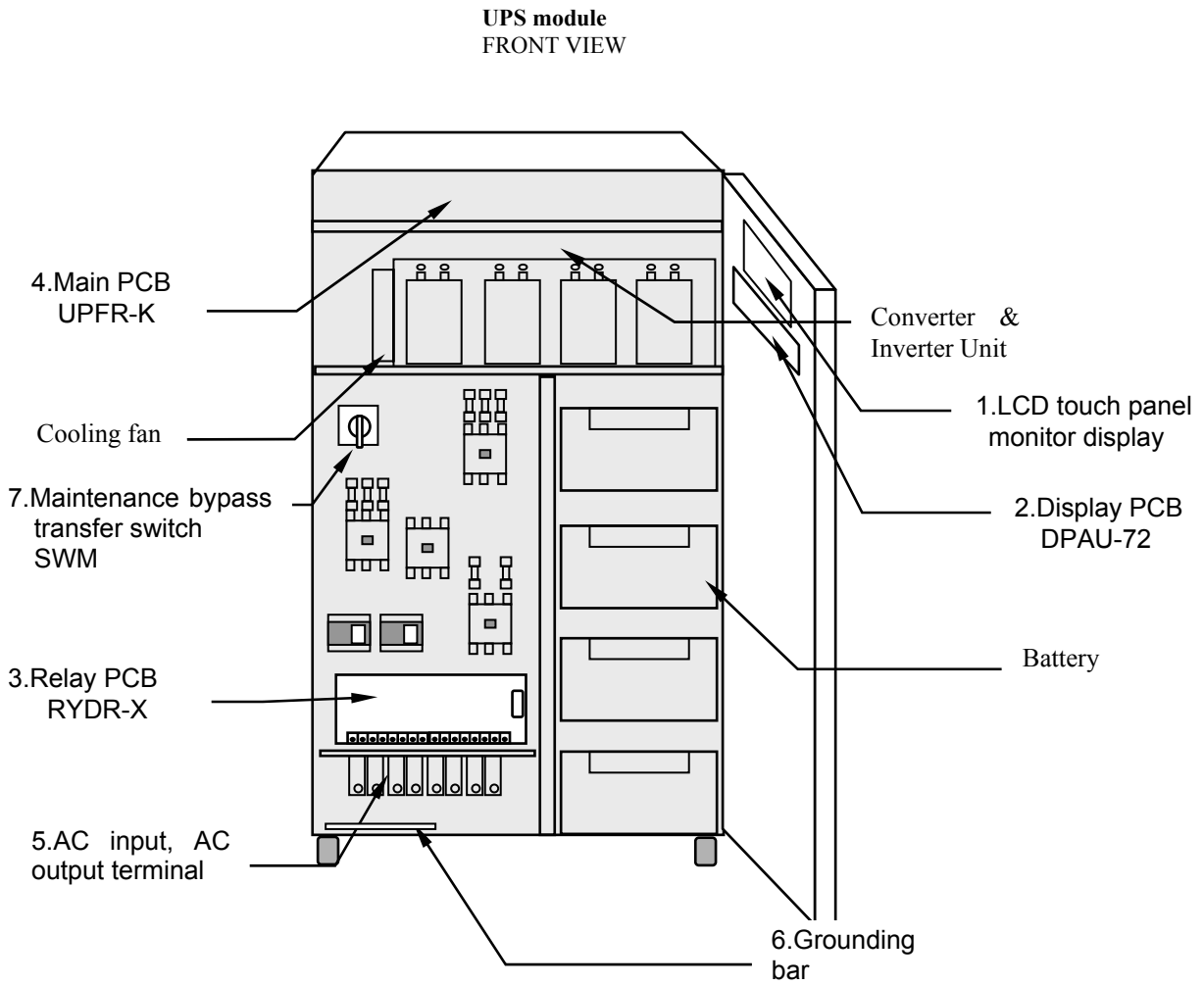

FIGURE 1.5c UPS Parts Location(40,50kVA)

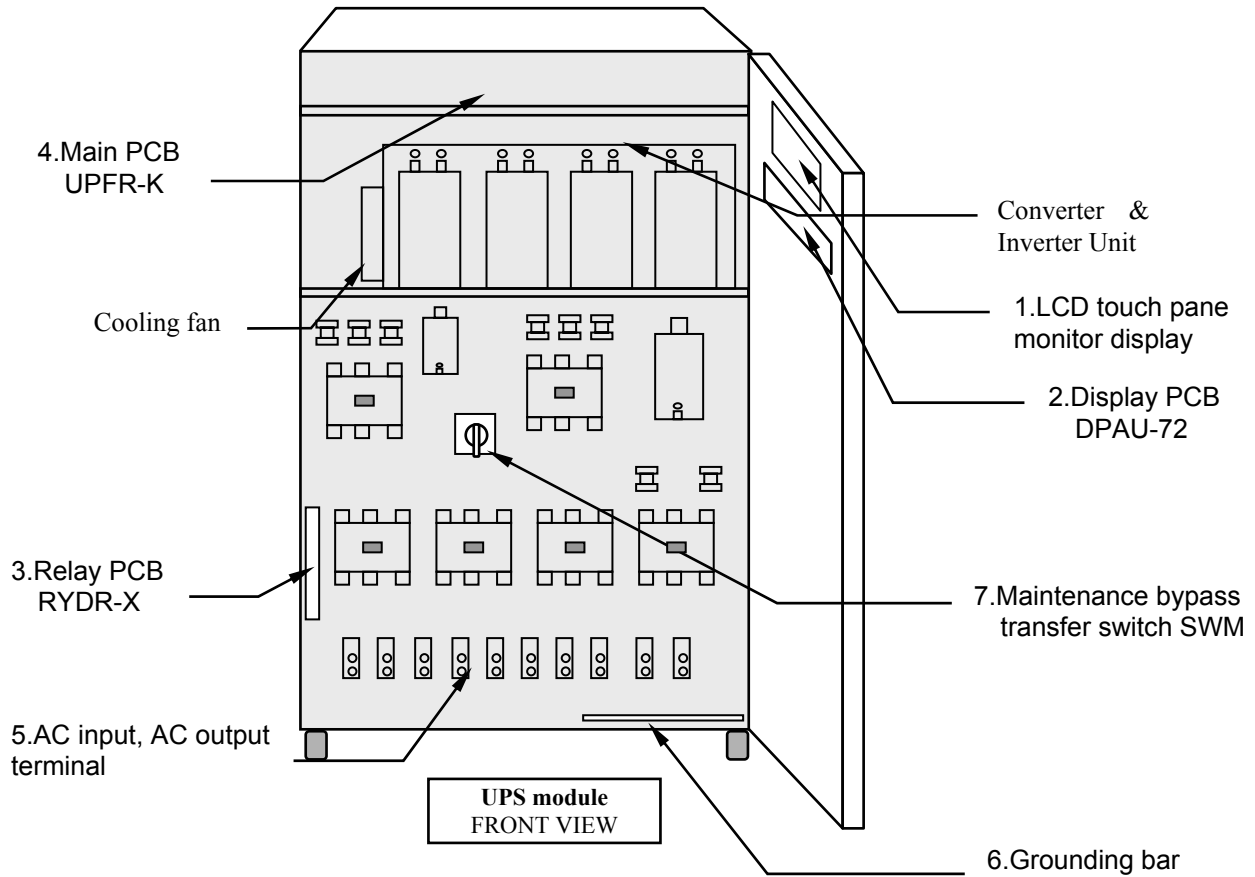

FIGURE 1.6 Display PCB DPAU-72



FIGURE 1.7 External I/F PCB RYDR-X

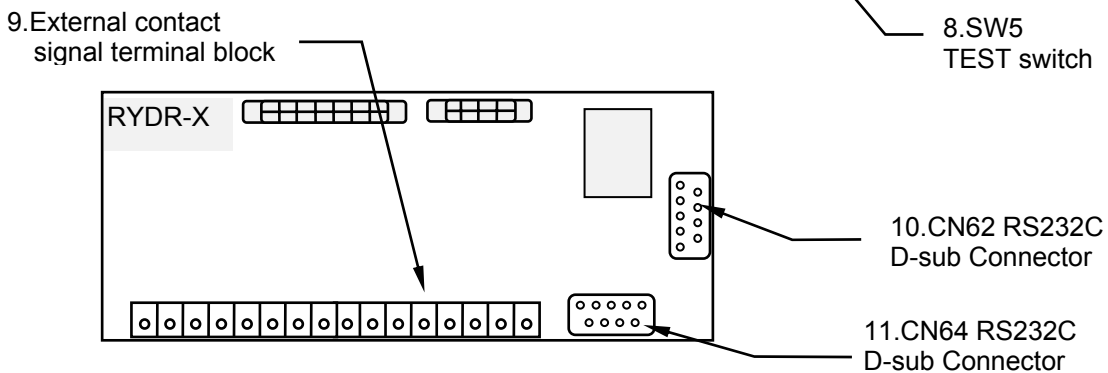
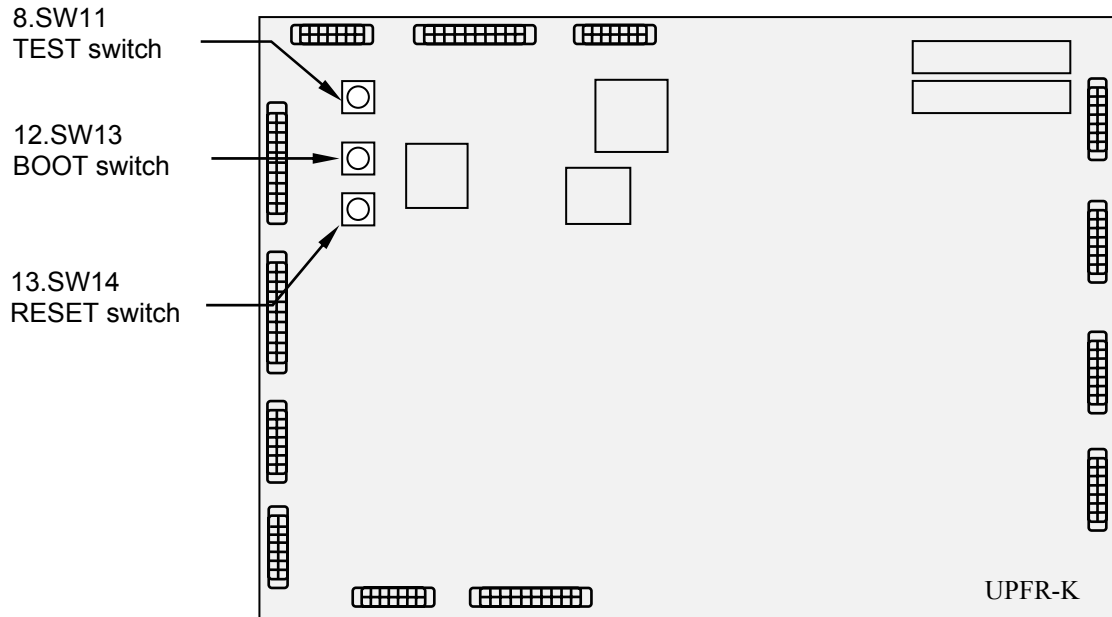

FIGURE 1.8 Main control PCB UPFR-K

Description of UPS parts, referred to in Figure 1.5:

1. LCD Touch Panel Monitor Display

The Liquid Crystal Display (LCD) Touch Panel Monitor Display indicates power flow, measured values and fault and error messages via user selectable display screens.

2. Display PCB DPAU-72

Switches on DPAU-72 board : FOR SERVICE PERSONNEL ONLY (Figure 1.6):

- (8) SW5 (TEST switch)

3. Relay PCB RYDR-X board

Signal I/F on RYDR-X board : (Figure 1.7):

- (9) External contact signal terminal block
- (10) CN62 (RS232C communication connector)
- (11) CN64 (RS232C communication connector)

4. Main PCB UPFR-K

Switches on UPFR-K board : FOR SERVICE PERSONNEL ONLY (Figure 1.8):

- (8) SW11 (TEST switch)
- (12) SW13 (BOOT switch).
- (13) SW14 (RESET switch)

5. AC input, AC output terminal

Refer to Figure 3.3 for details

6. Grounding bar (E)

7. **Maintenance Bypass Switch (52CS/SWM) (FOR SERVICE PERSONNEL ONLY)** This switch is used to transfer the load from inverter power to external power for maintenance purposes. Do not operate it under normal operation.
8. **"Test mode" switch (FOR SERVICE PERSONNEL ONLY)**
This switch changes system operation to the test-mode. This switch is mounted on Display PCB and Main PCB. (This switch should not be operated by personnel other than an Authorized Service Engineer).
9. **External contact signal terminal block**
Terminal block to connect contact signal input/output lines to and from external dry contacts. Refer to FIGURE 2.3 for details.
10. **RS232C connector (CN62)**
Refer to Figure 2.6 for detail.
11. **RS232C connector (CN64)**
12. **"BOOT" switch (FOR SERVICE PERSONNEL ONLY)**
This switch boots the processor on the main control circuit board following alarm conditions. (Do not operate this switch while inverter and converter are in operation).
13. **"Reset" switch (FOR SERVICE PERSONNEL ONLY)**
This switch resets errors resulting from alarm conditions. (Do not operate this switch while inverter and converter are in operation).

1.4 Specifications

The UPS name plate displays the rated kVA as well as nominal voltages and currents. The name plate is located on the interior side of the UPS front door.

TABLE 1.1 Power Specifications

Rated output Power	Input voltage 3 phase / 4 wire	Output voltage 3 phase / 3 or 4 wire
7.5kVA/6kW	208	208
10kVA/8kW	208	208
15kVA/12kW	208	208
20kVA/16kW	208	208
30kVA/24kW	208	208
40kVA/32kW	208	208
50kVA/40kW	208	208

TABLE 1.2 UPS Module Information

UPS (kVA)	CABLE ENTRY	WIDTH (in/mm)	DEPTH (in/mm)	HEIGHT (in/mm)	WEIGHT (lb./kg)	HEAT LOSS @ 208V (kBTU/h)
7.5	BOTTOM	17.7 / 450	31.5 / 800	43.3 / 1100	562 / 255*	3.2
10	BOTTOM	17.7 / 450	31.5 / 800	43.3 / 1100	562 / 255*	3.9
15	BOTTOM	17.7 / 450	31.5 / 800	43.3 / 1100	816 / 370*	5.1
20	BOTTOM	17.7 / 450	31.5 / 800	43.3 / 1100	816 / 370*	6.5
30	BOTTOM	23.6 / 600	31.5 / 800	59.0 / 1500	1235 / 560*	8.8
40	BOTTOM	27.6 / 700	31.5 / 800	59.0 / 1500	1082 / 490	11.9
50	BOTTOM	27.6 / 700	31.5 / 800	59.0 / 1500	1082 / 490	14.6

* : 7.5-30kVA Including batteries

TABLE 1.3 Detail of Specifications

Rated Output kVA	7.5	10	15	20	30	40	50
Rated Output kW	6	8	12	16	24	32	40
AC INPUT CHARACTERISTICS							
Configuration	3 phase, 4 wire						
Voltage	120/208 V +15% ~ -25%						
Frequency	60 Hz +/- 5%						
Reflected Current THD	4% typ. at 100% load; 7% typ. at 50% load						
BATTERY							
Type	VRLA						
Ride Through (at 100% load)	8min.	5min.	11min.	7min.	5min.		
Nominal Voltage	360 Vdc						
Minimum Voltage	300 Vdc						
Number of Cells	180						
AC OUTPUT							
Configuration	3 phase, 3 or 4 wire						
Voltage	120/208 V						
Voltage Stability	+/-1%						
Frequency	60 Hz						
Frequency Stability	+/-0.01% in free running mode						
Power Factor	0.8 nominal						
Power Factor range	0.8 ~ 1.0 lagging (within output kW rating)						
Voltage THD	2% typical THD at 100% Linear Load 4% typical THD at 100% non-linear load						
Transient Response	+/-3% typical at 100% load step +/-1% typical at loss/return of AC power +/-3% typical at load transfer to/from static bypass						
Transient Recovery	16.7 ms						
Voltage Unbalance	2% typical at 100% unbalanced load						
Phase Displacement	1deg. typical at 100% load						
Inverter Overload	150% for 1 minute						
System Overload	150% for 1 minute, 1000% for 1 cycle (with bypass available)						
Bypass Overload	150% for 1 minute, 1000% for 1 cycle						
Crest Factor Capabilities	3:1						
ENVIRONMENTAL							
Cooling	Forced Air						
Operating Temperature	32° F ~ 104° F (0° C ~ 40° C). Recommended 59° F ~ 77° F (15° C ~ 25° C)						
Relative Humidity	5% ~ 95% Non Condensing						
Altitude	0 ~ 5000 feet No De-rating						
Location	Temperature-controlled, indoor area free of conductive contaminants						

TABLE 1.4 Rating of Contactors and Fuses

Component	Description	Component Rating @ 208V,3 phase, 60 Hz						
		UPS Rating (kVA)	7.5	10	15	20	30	40
CB1	AC Input Contactor		60A			100A	150A	150A
CB2	DC Input Contactor		60A			100A	150A	150A
CB3	Static Bypass Input Contactor		60A			100A	150A	150A
52C	AC Output Contactor		60A			100A	150A	150A
FIU-W	AC Input Fuse		140A/660V			180A/600V	280A/660V	280A/660V
FBP,FBN	Battery Input Fuse		140A/660V			180A/600V	280A/660V	280A/660V
FOU-W	AC Output Fuse		140A/660V			180A/600V	280A/660V	280A/660V
(OPTION) FSU-W	Static Bypass Input Fuse		/			200A/660V	280A/660V	280A/660V
F1,F2,F3	UPER-Y/UPFR-K		6.3A/250V			6.3A/250V	6.3A/250V	6.3A/250V
F1	CABR-JA		12A/600V			/	/	/

2.0 OPERATOR CONTROLS AND INDICATORS

The 2033C Series operator controls and indicators are located as follows:

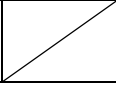
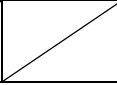
- Maintenance bypass switch and contactors : Inside the module
- UPS status indicators : Door exterior

FIGURE 2.1 Operation/Display Panel (Front panel)

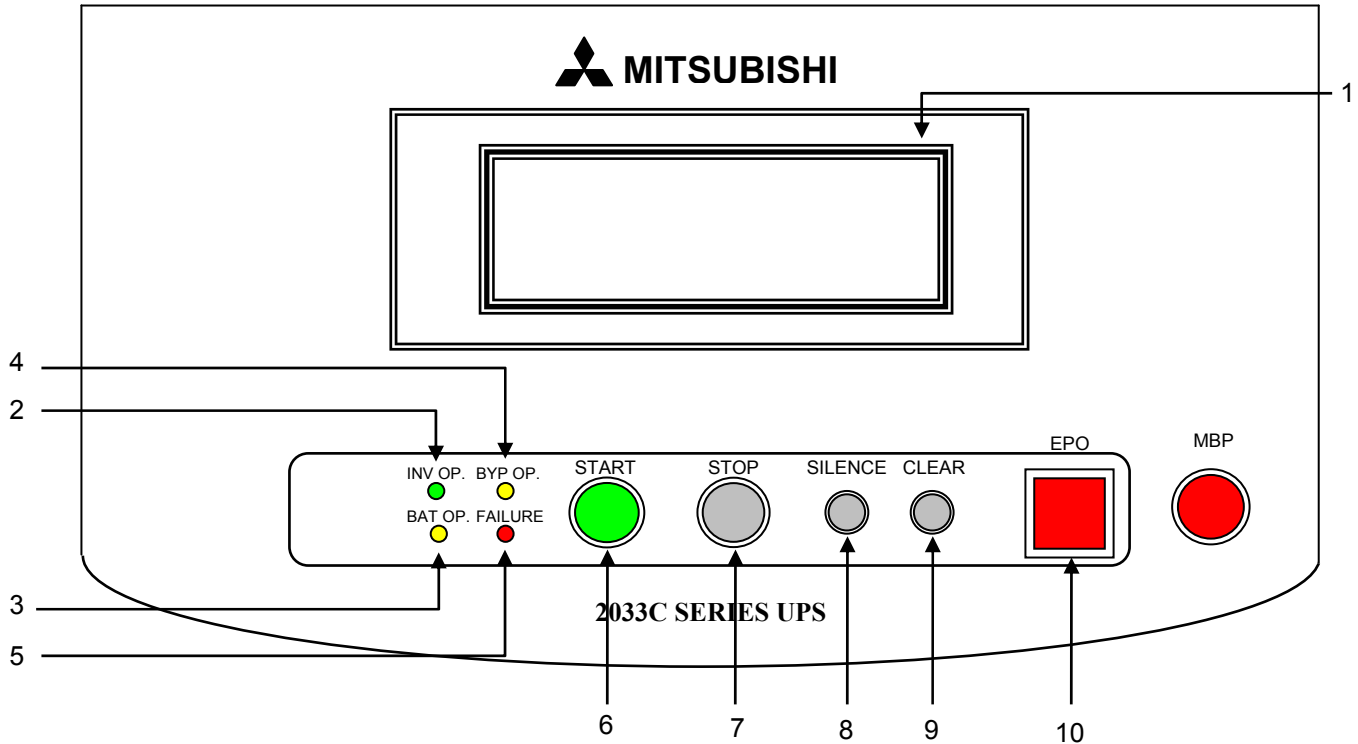

2.1 LCD Touch Panel Monitor Display and Keypad

1) LCD Touch Panel Monitor Display

The Liquid Crystal Display (LCD) Touch panel Monitor Display indicates power flow, measured values and fault and error messages via user selectable display screens.

MAIN MENU SCREEN

The MAIN MENU Screen is shown in Figure 2.2. The MAIN MENU screen displays the system Mimic diagram, and includes four MEASUREMENT Screen Touch icons: AC Input, Bypass Input, Battery, AC Output and one FAULT DISPLAY Screen Touch Icon: Fault/Alarm History. Date and Time are displayed at the bottom of the display.

FIGURE 2.2 MAIN MENU Screen

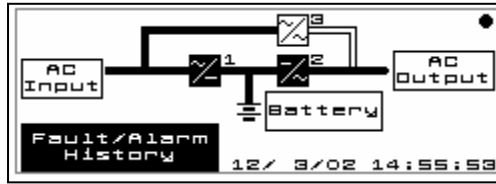

MEASUREMENT SCREENS

Pressing the MEASUREMENT Screen Touch icons on the MAIN MENU Screen will display each specific MEASUREMENT Screen. Each MEASUREMENT Screen displays specific system measurement data as shown in Figure 2.3.

FIGURE 2.3 MEASUREMENT Screens

AC Input Measurement Screen

Input line to neutral rms voltage (A-N, B-N, C-N)
 Input Current
 Input Real KW Power
 Input Frequency

AC Output Measurement Screen

Output line to neutral rms voltage (A-N, B-N, C-N)
 Output rms current of each phase
 Output Real KW Power
 Output Frequency

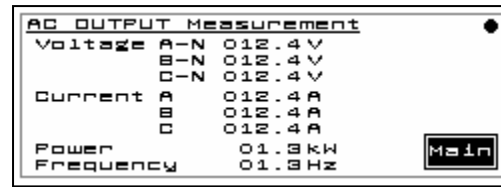
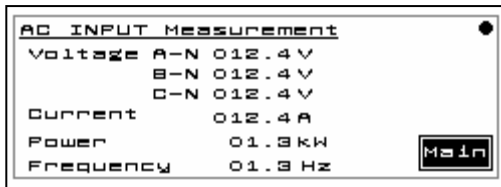

MAIN MENU Screen

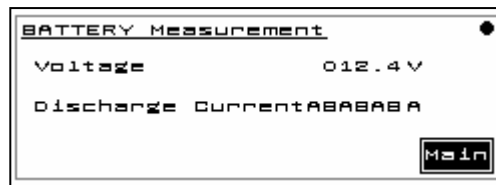
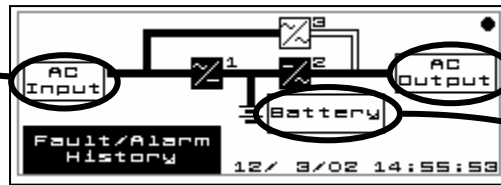

Battery Measurement Screen

DC Bus Voltage
 Battery Charge/Discharge Current

Each MEASUREMENT Screen includes a MAIN Menu Screen Touch Icon. On pressing this MAIN Touch icon, the display returns to the MAIN MENU Screen.

FAULT DISPLAY SCREEN

Pressing the FAULT DISPLAY Screen Touch icon on the MAIN MENU Screen will display the Fault display screen. Fault/Alarm data including fault codes and occurrence/restore dates as well as fault/alarm History can be displayed as shown in Figure 2.4. The FAULT DISPLAY Touch icon will flash on the MAIN MENU Screen if there are Fault/Alarms that have not been restored. Pressing the DETAIL DISPLAY Touch icon will display faults in more detail. Pressing the Rest. Item Delete Touch icon will delete all fault/alarms that are selected by the Cursor Touch icons and have been restored. On Pressing the Main Touch Icon, the display returns to the MAIN MENU Screen.

FIGURE 2.4 FAULT DISPLAY Screen

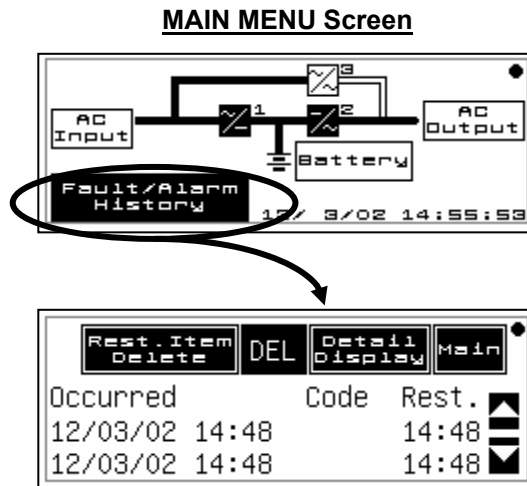

DATE & CLOCK SETUP SCREEN

Pressing the lower right of the MAIN MENU Screen will display the date & clock setup screen.

On Pressing the END Touch Icon, the display returns to the MAIN MENU Screen.

FIGURE 2.5 DATE & CLOCK SETUP Screens

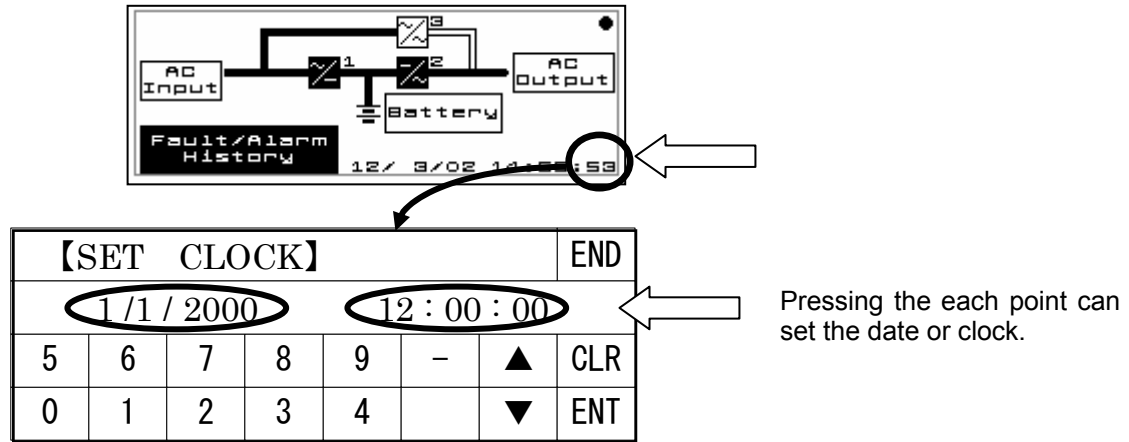

NOTE: The display measurement values shown for LCD Monitor Displays are samples only.

2) **Load on inverter [INV OP.] (green)**

Illuminated when power is supplied from inverter to the critical load.

3) **Battery operation [BAT OP.] (yellow)**

Illuminated when the battery is operating following an AC power failure.

4) **Load on bypass [BYP OP.] (yellow)**

Illuminated when power is supplied to load devices by static bypass.

5) **UPS failure [FAILURE] (red)**

Illuminated when UPS is in fault mode.

6) **Inverter start [START] (green)**

Inverter start button.

When pressed, the load will transfer from the static bypass line to the inverter.

7) **Inverter stop [STOP] (gray)**

Inverter stop button. When pressed, the inverter can be stopped.

The load will transfer from the inverter to the static bypass line.

8) **Alarm Silence [SILENCE] (gray)**

Audible alarm is silenced when this button is pressed.

9) **Clear [CLEAR] (gray)**

Clears errors in UPS system.

10) **Emergency Power Off [EPO] (red)**

Shuts down UPS when pressed. Load is dropped.

11) **Load on maintenance bypass [MBP] (red)**

Illuminated when power is supplied to load devices by maintenance bypass.

2.2 External Signal Terminal Block

The UPS is equipped with a series of input/output terminals for the external annunciation of alarms and the remote access of certain UPS functions. Layout of terminals is shown in Figure 2.6, with a functional description of the input/output port presented:

FIGURE 2.6 External Signal Terminal Block (NEC Class2)

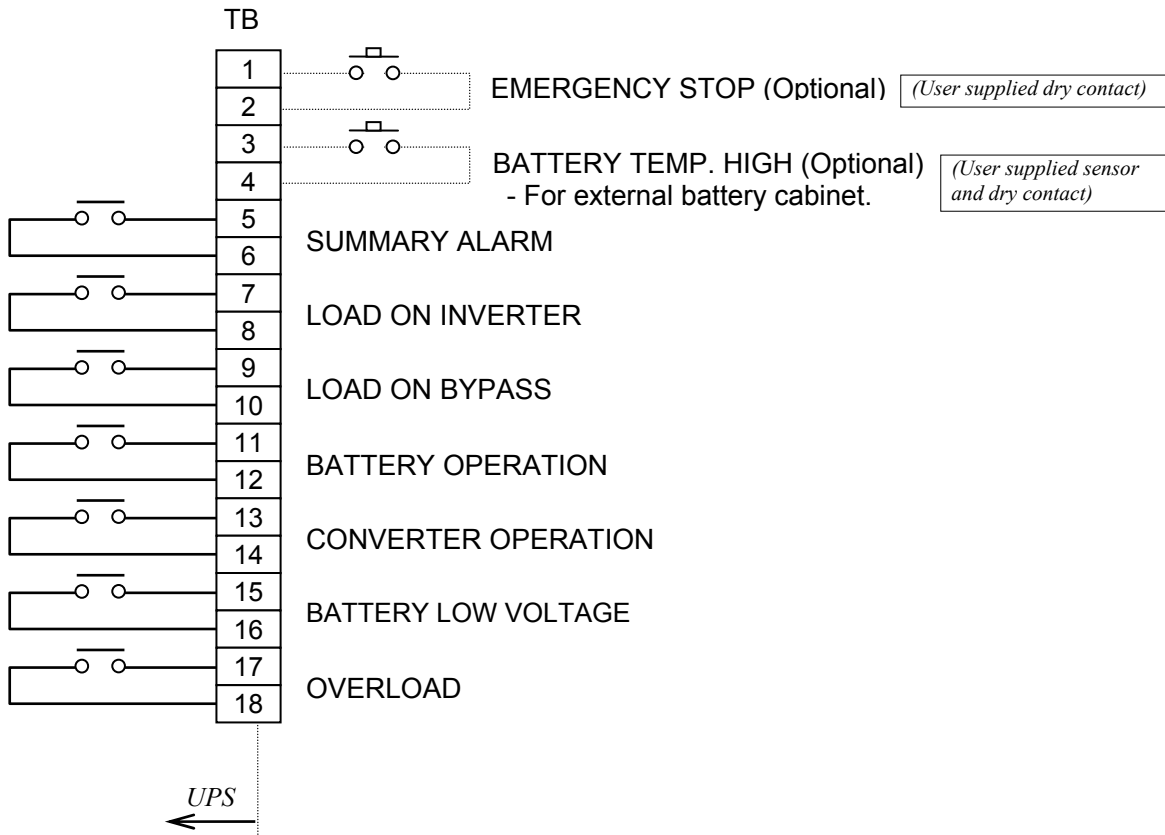

A) Output Contacts (for external alarm annunciation)

Output contacts consist of form “A” dry type contacts. The rated capacity of all output contacts is 120Vac/0.5Aac or 30Vdc/1Adc. All dry contacts must be operated at their rated values or lower. Figure 2.7 illustrates a typical installation. The external relay can also be a lamp, LED, or computer, etc.

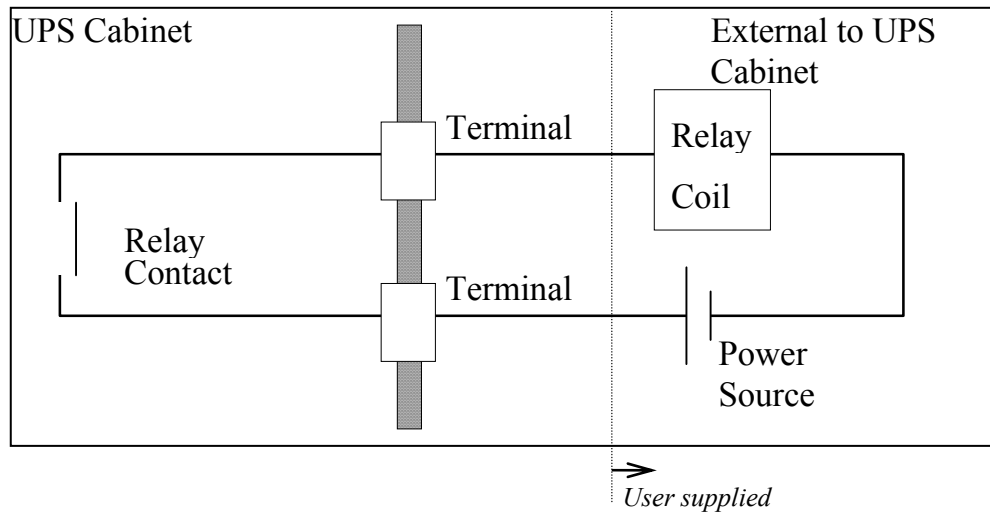
FIGURE 2.7 Control Wiring for External Contacts

Details of output alarm contacts :
Terminals 5 to 6 “Summary Alarm” contact

Activated when a fault alarm occurs.

Terminals 7 to 8 “Load on Inverter” contact

Activated when the power is supplied by the inverter.

Terminals 9 to 10 “Load on Bypass” contact

Activated when the power is supplied by the static bypass input.

Terminals 11 to 12 “Battery Operation” contact

Activated when the battery is operating following an AC power failure.

Terminals 13 to 14 “Converter Operation” contact

Activated when the converter is operating.

Terminals 15 to 16 “Battery Low Voltage” contact

Activated when battery voltage drops below discharge end voltage level during inverter operation (i.e. During AC failure conditions).

Terminals 17 to 18 “Overload” contact

Activated when a system overload occurs.

B) Input Contacts (for remote access of UPS)

External contacts are provided by the user of the UPS system. The terminal voltage at the UPS is 24Vdc. External dry contacts are to be provided accordingly.



NOTE: *Do not apply voltages to remote access input terminals. Damage to UPS may result.*

Refer to Figure 2.8 for a typical wiring configuration. Although this figure shows the emergency stop configuration, the same wiring arrangement is used for battery temperature high. See below for terminal connection details.

FIGURE 2.8 Remote "Stop" Contact Connections

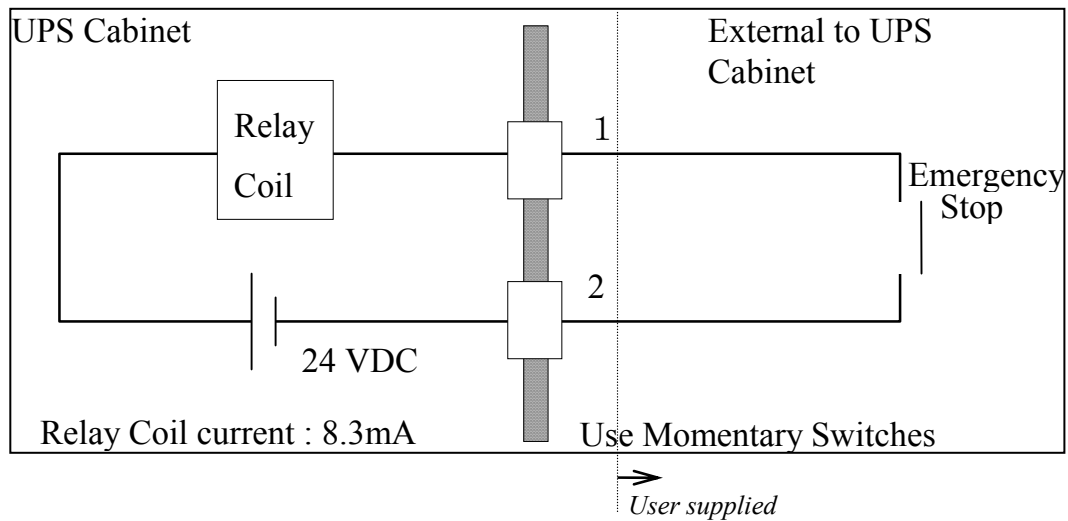

Details of input contacts for remote access :

Terminals 1 to 2 "Emergency Stop" contact input

Used to perform a remote UPS emergency power off (EPO).

The load will be dropped.

Terminals 3 to 4 "Battery Temp. High" contact input

Input fed by a thermocouple that monitors battery temperature. The converter float voltage level is reduced for battery over-temperature conditions. The external thermocouple will be user supplied



NOTE : *In all cases, a switch having a protective cover is recommended in order to reduce possibility of accidental operation.*

2.3 External communication connector

This is an RS232C port for “DiamondLink”^{*} monitoring software. The layout of the connector is shown in Figure 2.9.

FIGURE 2.9 External communication connector (NEC Class2)

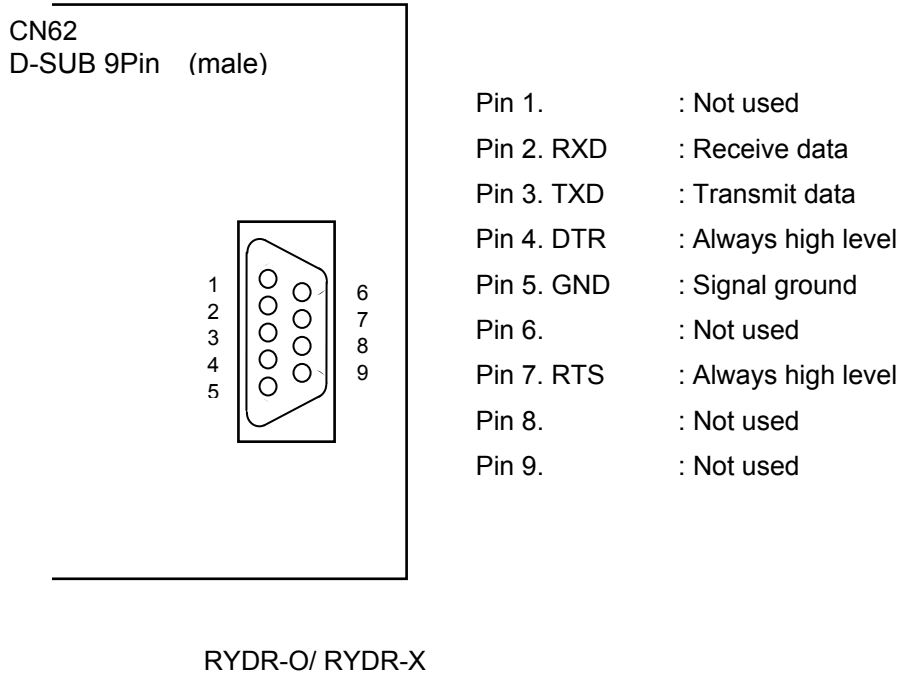

** Consult MITSUBISHI ELECTRIC AUTOMATION, INC. for detail on “Diamond Link” monitoring software and its capabilities.*

3.0 INSTALLATION AND OPERATION

3.1 Transportation and Installation

TABLE 3.1 How to transport and install the system

Transportation	Installation
Transport unit with forklift.	Pull out the UPS cabinet as shown in Figure 3.1 Fix the UPS unit in place using the four (4) leveling feet.



Note : *Do not transport in a horizontal position. Cabinets should be maintained upright within +/- 15° of the vertical during handling.*

3.2 Handling

The UPS is shipped in export packaging. Remove the UPS from the package only when it is ready for installation.

FIGURE 3.1 Handling

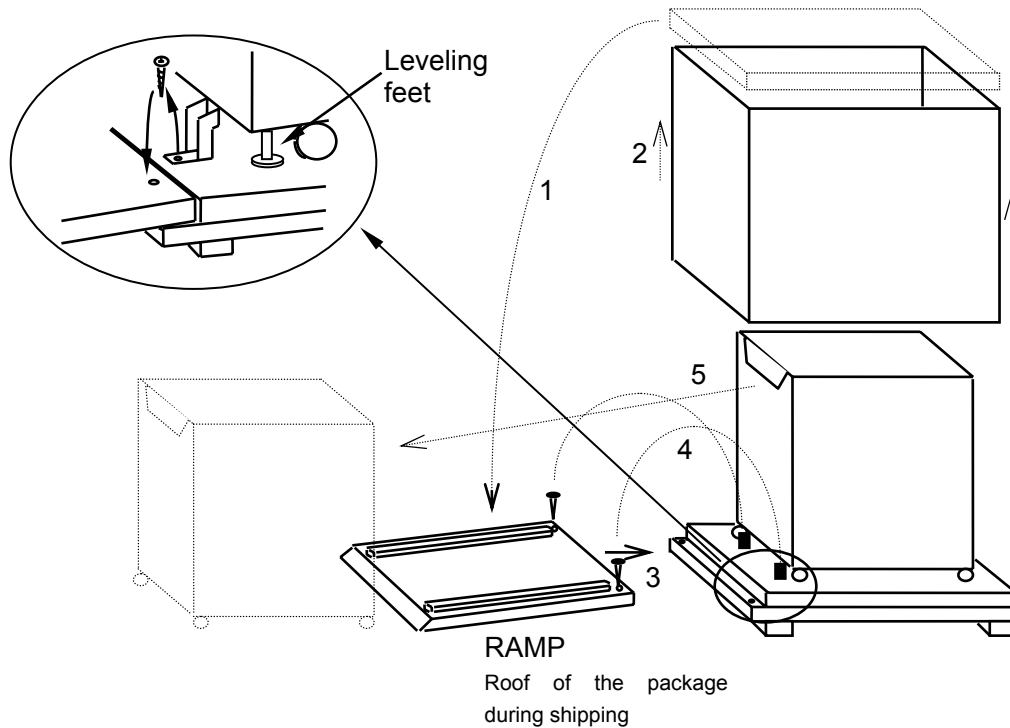

Note : *The figure 3.1 export packaging is for 7.5kVA through 20kVA UPS only.*

3.3 Installation Procedure



A) Note the load tolerance of the floor

Refer to Table 3.2 for list of UPS weights:

TABLE 3.2 List of UPS weights

UPS Capacity (kVA)	7.5	10	15	20	30	40	50
Weight (lb.)	562	562	816	816	1235	1082	1082

Note: 40kVA and 50kVA UPS have batteries external to module cabinet
Please refer to the remote battery supply installation manual.

B) Minimum clearance required for ventilation

Right side 1.0" (25 mm) (not required when sidecars are used)
Left side 1.0" (25 mm) (not required when sidecars are used)
Back side 7.8" (200 mm)
Top side 39.4" (1000 mm)

C) Space requirement for routine maintenance

Allow for the following space at the time of installation.

Front 39.4" (1000 mm)
Sides 1.0" (25 mm)
Rear 7.8" (200 mm)

D) Battery

Please refer to the following when installing and maintaining batteries:



1. Servicing of batteries should be performed or supervised by personnel knowledgeable of batteries and the required precautions. Keep unauthorized personnel away from batteries.
2. When installing or replacing batteries, install or replace with the same number and type per Table 3.3

TABLE 3.3 Type and number of battery

	Type	Manufacturer	Number
7.5kVA,10kVA	PM12-7.2 NP7-12	Power Battery Inc. Yuasa Corp.	30
15kVA,20kVA	PM12-18 NP18-12B	Power Battery Inc. Yuasa Corp.	30
30kVA	PM12-18 NP18-12B NP18-12BFR	Power Battery Inc. Yuasa Corp. Yuasa Corp.	30
40kVA,50kVA			

Note: 40kVA and 50kVA UPS batteries are external to module cabinet.

Please refer to the remote battery supply installation manual.



3. CAUTION - Do not dispose of battery or batteries in a fire. The battery may explode.
4. CAUTION - Do not open or mutilate the battery or batteries. Released electrolyte is harmful to the skin and eyes and may be toxic.
5. CAUTION - A battery can present a risk of electrical shock and high short circuit current. The following precautions should be observed when working on batteries:
 - Remove watches, rings, or other metal objects.
 - Use tools with insulated handles.
 - Wear rubber gloves and boots.
 - Do not lay tools or metal parts on top of batteries.
 - Disconnect charging source prior to connecting or disconnecting battery terminals.

3.4 Procedure for Cable Connections (Refer to Table 3.4 for cable sizes.)

- I. Confirm the capacity of the UPS being installed. Identify the input/output power terminal blocks as shown in the appropriate Figure 3.2 or Figure 3.3-Figure 3.5.
- II. Connect the grounding conductor from the input service entrance to the UPS ground bar.
- III. Confirm that an external input circuit breaker sized to protect both the converter input and the bypass lines is installed. Consult equipment nameplate for current ratings. Connect the AC power source cables from the input service entrance to the UPS' INPUT power terminals identified as A, B, C and N in Figure 3.3-Figure 3.5. Input cables must be sized for an ampere rating larger than the maximum current capacity of the UPS.
- IV. Refer to Table 3.4 for recommended cable sizes. Referring to Figure 3.3-Figure 3.5, connect UPS' OUTPUT load terminals A, B, C and N to load distribution panel.
- V. Connect external signal terminal block as needed. Refer to section 2.2 and Figure 2.3 for functional description. 12 AWG, or less, shielded conductor is recommended.

NOTES: 1. *Confirm that all UPS internal contactors (breakers) "CB1", "CB2", and "CB3" are open before energizing UPS.*



2. *UPS power terminals are supplied with stud type fittings. It is recommended that compression lugs be used to fasten all input/output power cables. Refer to Table 3.5 for recommended compression lugs and appropriate crimping tool*

Table 3.4 Recommended Cable Size and Torque Requirements

UPS Capacity (kVA)	Input Side * 1		Output Side * 1	
	Cable *2 Size	Torque (in. lbs)	Cable *2 Size	Torque (in. lbs)
7.5kVA (208V)	8 AWG or larger	180 in. lbs	8 AWG or larger	180 in. lbs
10kVA (208V)	8 AWG or larger	180 in. lbs	8 AWG or larger	180 in. lbs
15kVA (208V)	8 AWG or larger	180 in. lbs	8 AWG or larger	180 in. lbs
20kVA (208V)	6 AWG or larger	180 in. lbs	6 AWG or larger	180 in. lbs
30kVA (208V)	2 AWG or larger	180 in. lbs	2 AWG or larger	180 in. lbs
40kVA (208V)	2/0 AWG or larger	180 in. lbs	2/0 AWG or larger	180 in. lbs
50kVA (208V)	2/0 AWG or larger	180 in. lbs	2/0 AWG or larger	180 in. lbs

*1 - Voltage drop across power cables not to exceed 3% of nominal source voltage.

*2 - Allowable ampere ratings based on 90° C insulation at an ambient temperature of 30° C.

No more than 3 conductors in a raceway without de-rating. Copper conductors assumed.

TABLE 3.5 Crimp Type Compression Lug

WIRE SIZE (CODE)	WIRE STRAND CLASS	RECOMMENDATION		CRIMP TOOL REQUIRED BURNDY TYPE Y35 OR Y46	
		VENDOR	CAT. NO.	COLOR KEY	DIE INDEX
8	B	BURNDY	YA8C-L2	RED	49
6	B	BURNDY	YA6C-L3	BLUE	7 / 374
4	B	BURNDY	YA4C-L3	GRAY	8 / 346
2	B	BURNDY	YA2C-L	BROWN	10
2/0	B	BURNDY	YA26-L3	BLACK	13

NOTE: *When using crimp type lugs, the lugs should be crimped to the specifications given in the manufacturer's instructions for both crimp tool and lug.*

Fig.3.2 UPS Terminal Designation

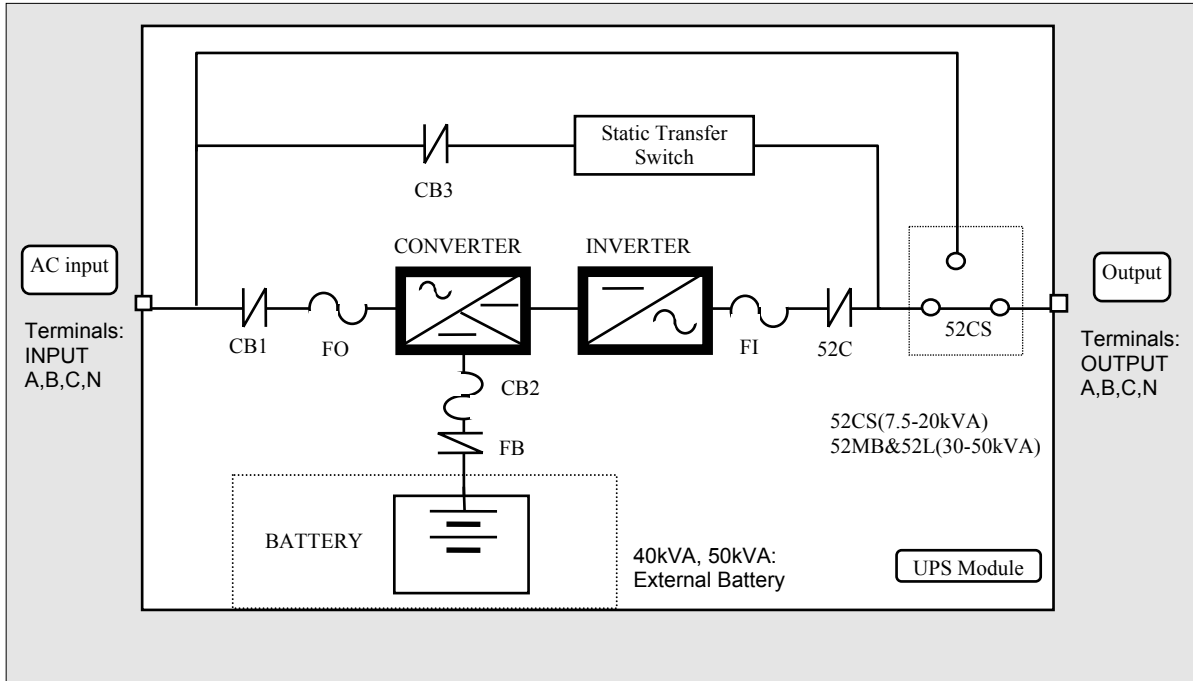

FIGURE 3.3 Input/Output Power Terminals (7.5kVA - 20kVA)

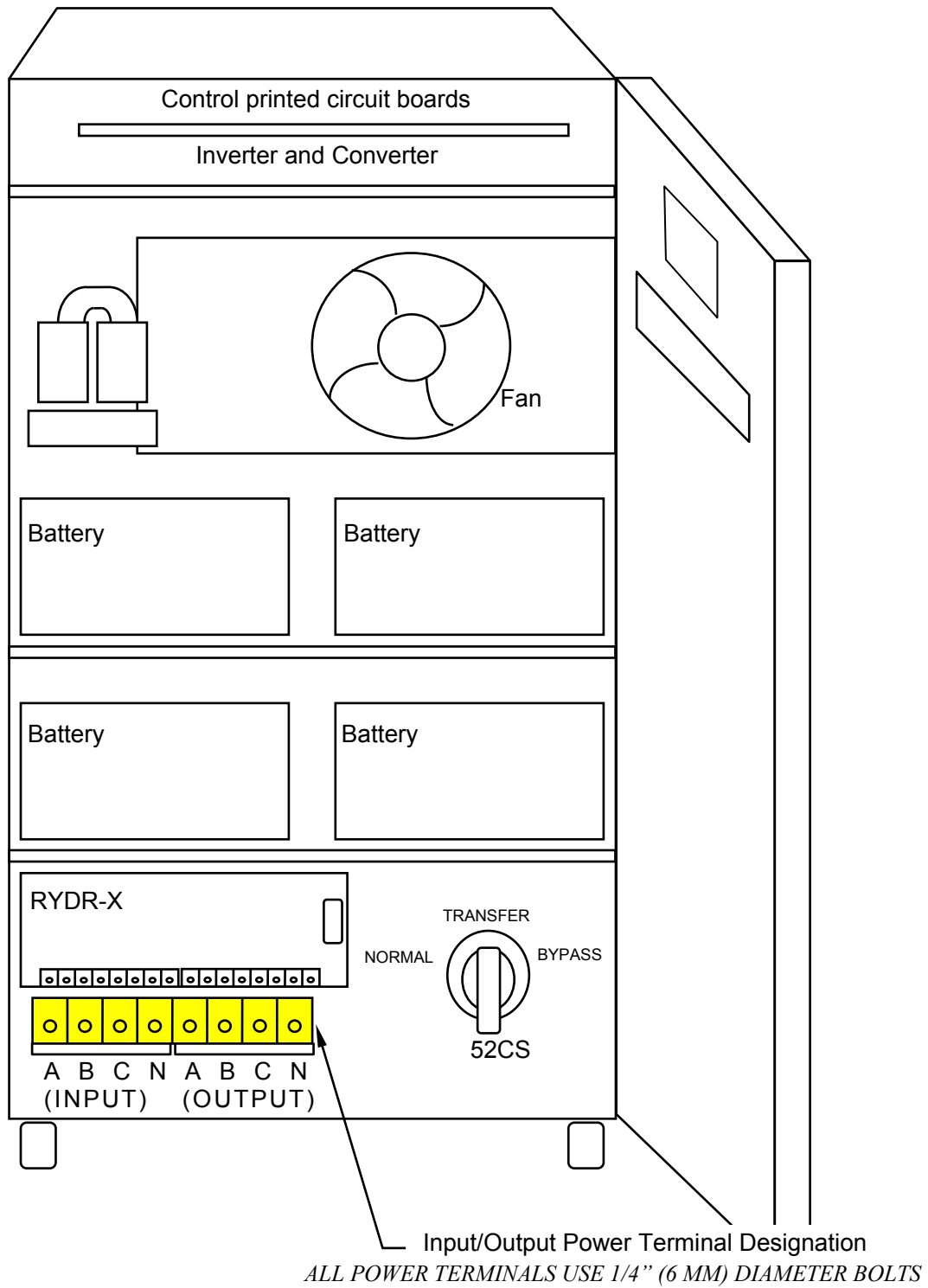

FIGURE 3.4 Input/Output Power Terminals (30kVA)

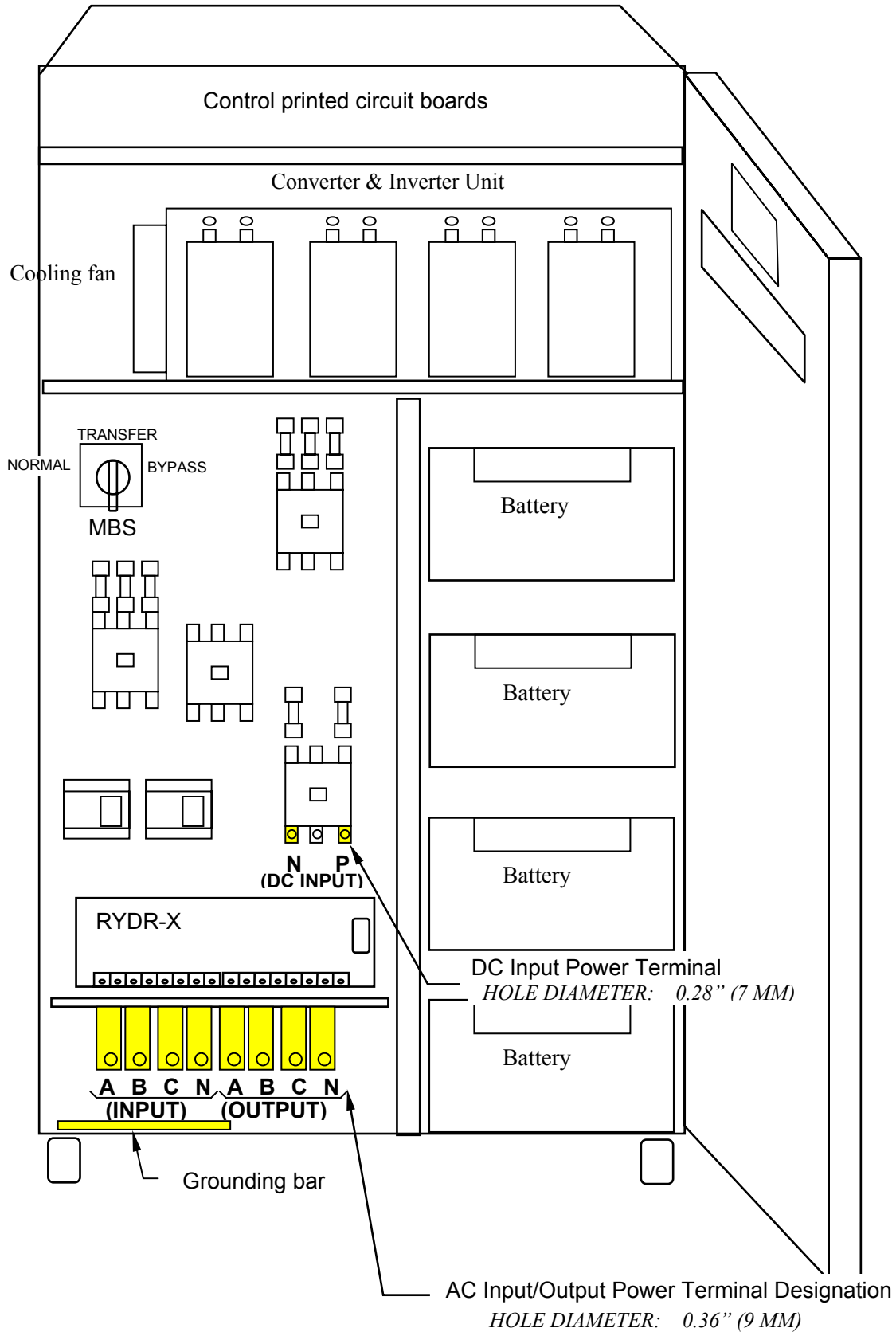
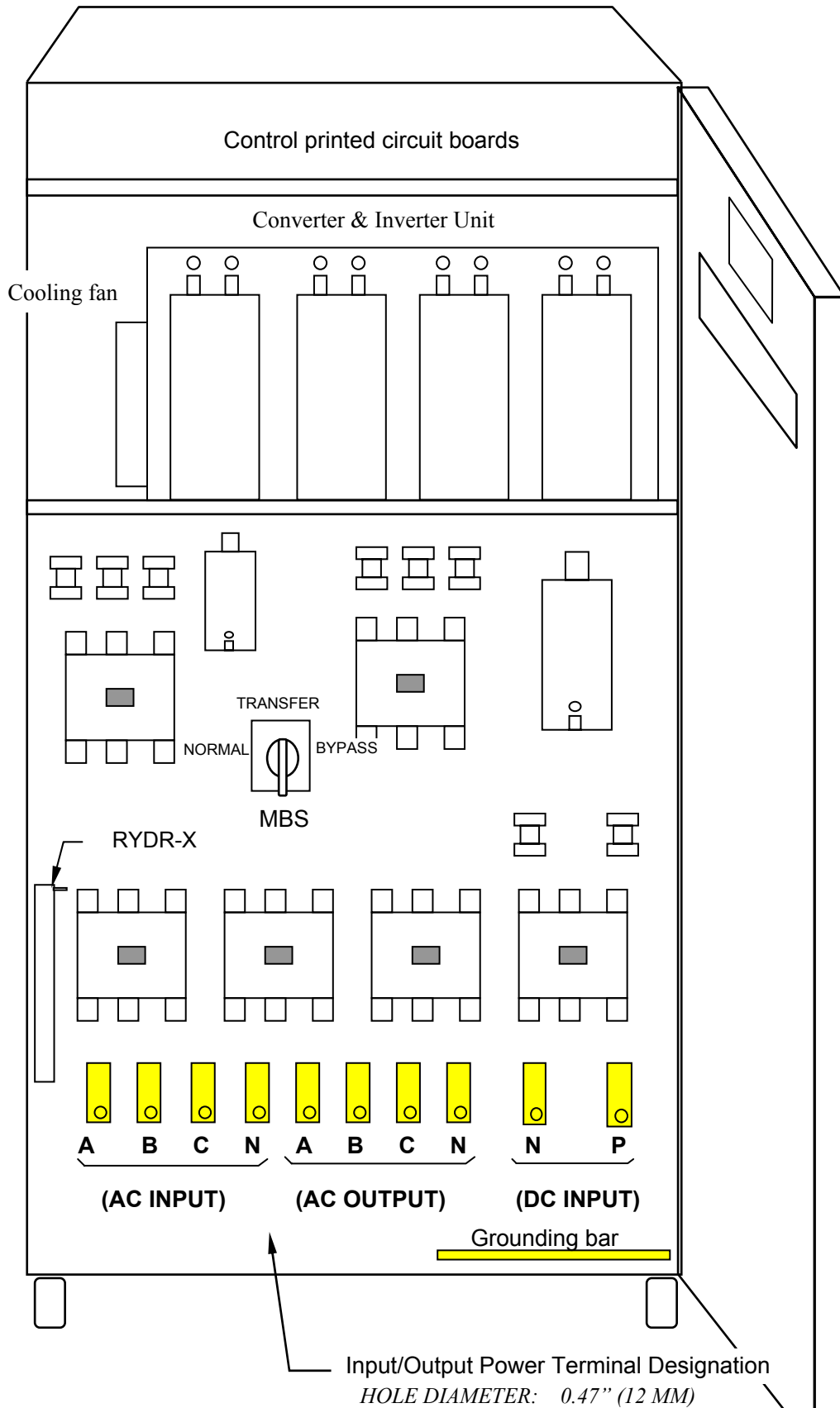

FIGURE 3.5 Input/Output Power Terminals (40kVA - 50kVA)



3.5 Operating Procedures

A) UPS Start-up Procedure

1. Close External Input Circuit Breaker (User supplied. Refer to warning 2).
2. The "BYP.OP." illuminates and power is supplied to the critical load from the static bypass line automatically.
3. Within ten (10) seconds, the "INV.OP." LED flashes and the Inverter starts. The UPS will automatically transfer the load from the static bypass line to the inverter and the "INV.OP." light illuminates.

NOTE : *If code "81" is indicated on the FAULT DISPLAY Screen, please check the position of EPO button. If EPO button is in the ON position, press the button to clear EPO as shown in figure 3.6. Press the "CLEAR" button. If code "99" is indicated on the FAULT DISPLAY Screen, press "CLEAR" button again.*

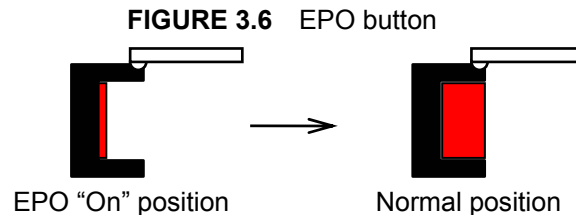

B) UPS Shutdown Procedure

1. If a total UPS module (inverter and converter) shutdown is required, press the "STOP" button on the front panel. Within 3 seconds the "BYP.OP." LED will illuminate and the UPS will transfer the load to the static bypass line.

WARNING : *Verify the load is OFF if the next step is to be performed .*



NOTE : *Power to the critical load is supplied through the static bypass line. Power to the critical load will be lost after execution of the next step. The load will drop.*

2. If turning off all power to the critical load is desired, open the AC Input Circuit Breaker (User supplied.).



CAUTION : *In bypass mode, all UPS power terminals are still live. Lethal voltages are present. De-energize all external sources of AC and DC power before handling UPS.*

C) EPO (Emergency Power Off) Procedure

If an all power supply shutdown is required in an emergency situation, press the "EPO" button on the front panel. The UPS will be shutdown and no power is supplied to the load.



WARNING : *With EPO operation, although all output power from the UPS is shutdown, it is necessary to manually open the input circuit breaker (user supplied), to remove the input power to the UPS.*

3.6 Maintenance bypass set-up procedures**A) Transfer of load from inverter to maintenance bypass**

1. On the front panel, press the "STOP" button. The "BYP.OP." LED illuminates within 3 seconds.
2. After confirming that the "BYP.OP." LED is illuminated, Rotate the MBS(52CS/SWM) clockwise to the "TRANSFER" position (Do not rotate 52CS/SWM if the "BYP.OP." LED is NOT illuminated).
3. After 3 seconds, rotate 52CS/SWM clockwise to the "BYPASS" position.
4. Transfer complete. Load is now powered from the external source. UPS can be shutdown.

B) Transfer of load from maintenance bypass to inverter

1. Rotate 52CS/SWM counterclockwise from the "BYPASS" position to the "TRANSFER" position, wait 5 seconds.
2. On the UPS, confirm the "BYP.OP." LED is illuminated. If not, press the "STOP" button.
3. Rotate 52CS/SWM counterclockwise to the "NORMAL" position.
4. On the UPS, press the "START" button. The "INV.OP." LED should illuminate.
5. Transfer complete. Load now powered by the inverter.

4.0 RESPONSE TO UPS FAILURE

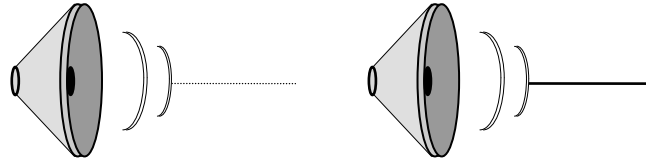
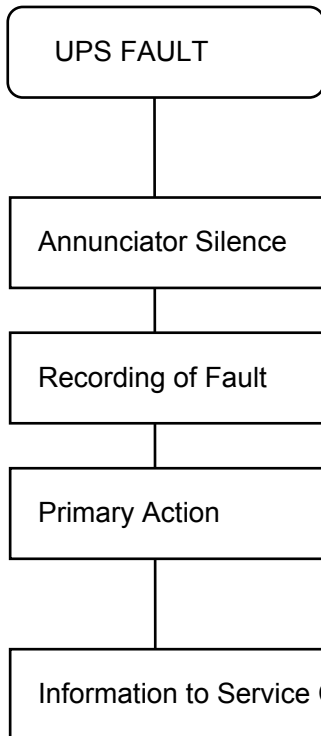

Depress "SILENCE" button on the front panel.

Refer to the list of fault codes for a description of the error. See section 6. For fault codes

Take necessary action per the list of fault codes in section 6 of this manual.

When faults occur, contact the Authorized Mitsubishi Service Representative or call Mitsubishi at **1-800-887-7830**.

Note :

The error code indicated on the FAULT DISPLAY Screen of the LCD Display at the time of UPS alarm condition is very important. In order to minimize repair time, please include this information along with the operation status and load status, on all correspondence with Mitsubishi's field service group.

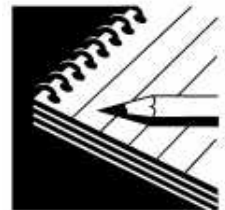

5.0 PARTS REPLACEMENT

Contact Mitsubishi or its Authorized Service Center on all issues regarding the replacement of parts.

A) Battery

Battery lifetime may vary according to the frequency of use and the average ambient operating temperature. Battery end of life is defined as the state of charge resulting in an ampere-hour capacity less than, or equal to, 80% of nominal capacity. Replace battery if capacity is within this percentage.

B) UPS Component Parts

Contact Mitsubishi or its Authorized Service Center for a complete parts replacement schedule. Recommended replacement time interval varies with operating environment. Contact Mitsubishi or its Authorized Service Center for specific application recommendations.

6.0 FAULT CODES

This section covers the fault codes, their description and required action.

At time of error :



A) Verify and record the occurrence of the alarm. Note fault code on the FAULT DISPLAY Screen of the LCD Display .

Contact Mitsubishi Electric Automation, Inc. at 1-800-887-7830.

B) If the External AC Input Circuit Breaker (MCCB) is in the trip state, depress the toggle to reset the breaker before re-closing.

Failure Code List

LCD Failure Code	Status	Guidance	Note 1 Buzzer	Note 2 External send- out contact	Note 3 Failure LED
00	Test mode (Pulse check)	-	[1]	-	-
01	Maintenance mode	-	[1]	-	-
10	Battery circuit abnormal	Call service engineer	[1]	Minor	Flicker
11	Battery test	-	-	-	-
12	Battery circuit abnormal	Call service engineer	[1]	Minor	Flicker
13	Battery depleted warning	-	[1]	Alarm	Flicker
14	Battery depleted	-	[2]	Alarm	Lit up
15	Battery temperature abnormal	Check battery	[1]	Alarm	Flicker
16	Battery temperature abnormal	Check battery	[1]	Minor	Flicker
17	Battery charge voltage abnormal	Call service engineer	[1]	Alarm	Flicker
18	DC voltage abnormal	Call service engineer	[1]	Minor	Flicker
19	Battery depleted (Converter overload)	Check AC input voltage	[2]	Major	Lit up
21	AC input voltage out of range	Check AC input voltage	[1]	Alarm	-
22	AC input phase rotation error	Check AC input voltage	[1]	Minor	Flicker
23	Converter overload	Call service engineer	[1]	Alarm	Flicker
24	Converter over current	Call service engineer	[1]	Minor	Flicker
25	Converter abnormal (DCOV)	Call service engineer	[2]	Major	Lit up
26	Converter abnormal (DCUV)	Call service engineer	[2]	Major	Lit up
27	Converter abnormal	Call service engineer	[2]	Major	Lit up
28	Converter abnormal at pre-charge	Call service engineer	[2]	Major	Lit up
31	Inverter voltage abnormal	Call service engineer	[1]	Minor	Flicker
32	Inverter abnormal (VLOV)	Call service engineer	[2]	Major	Lit up
33	Inverter abnormal (VLUV)	Call service engineer	[2]	Major	Lit up
34	Inverter abnormal (OC)	Call service engineer	[2]	Major	Lit up
35	Inverter abnormal	Call service engineer	[2]	Major	Lit up
36	52C abnormal	Call service engineer	[1]	Minor	Flicker
37	52C abnormal	Call service engineer	[1]	Minor	Flicker
41	Bypass voltage out of range	Check bypass input	-	Alarm	Flicker

LCD Failure Code	Status	Guidance	Note 1 Buzzer	Note 2 External send- out contact	Note 3 Failure LED
53	Transfer circuit abnormal	Call service engineer	[1]	Minor	Flicker
54	Control circuit error	Call service engineer	[2]	Major	Lit up
55	Control circuit error	Call service engineer	[2]	Major	Lit up
56	Control circuit error	Call service engineer	[2]	Major	Lit up
57	Control circuit error	Call service engineer	[2]	Major	Lit up
58	Control circuit error	Call service engineer	[1]	Minor	Flicker
59	Control circuit error	Call service engineer	[2]	Major	Lit up
71	Overload	Reduce load	[1]	Alarm	Flicker
72	kW overload	Reduce load	[1]	Alarm	Flicker
73	Instantaneous overload	Reduce load	[1]	Alarm	Flicker
74	Load abnormal	Check load	[1]	Alarm	Flicker
76	Overload	Reduce load	[1]	Alarm	Flicker
81	Emergency stop activated	-	[1]	Alarm	Flicker
82	Fin temperature abnormal	Call service engineer	[2]	Major	Lit up
96	Control circuit error	Call service engineer	[2]	Major	Lit up
97	Restart after battery depleted	-	-	Alarm	-
98	Control circuit error	Call service engineer	[2]	Major	Lit up
99	Start up	Press Clear button	-	Alarm	-

(Note 1)

Audible annunciator: [1] intermittent sound, [2] continuous sound.

(Note 2)

- "Major" is defined as a major failure. Load transferred from inverter to the static bypass line;
- "Minor" is defined as a minor failure. UPS continues to operate normally, but cause of alarm must be identified;
- "Over" is defined as an overload condition. Load will transfer from inverter to the static bypass line and may or may not return to the inverter. Return to inverter will occur only if overload corrects itself and output load is within rating of UPS. (Note: Inverter may need to be restarted manually subsequent to an output bolted fault.)

(Note 3)

Indicates one of two possible LED illumination patterns - continuously on (lit) or intermittent (flicker).

7.0 Warranty & Out of warranty Service

The Mitsubishi Electric UPS Systems Group Service Department has many Authorized Service Centers place strategically throughout the US, Canada and Latin America. For both in warranty and out of warranty service, please contact Mitsubishi Electric Automation, Inc. at (847) 478-2500. To register your UPS for warranty purposes, please complete the warranty registration form and fax it to the Mitsubishi Electric UPS Systems Group, Service Department fax line shown on the registration form. (Next page)

For warranty purposes, it is essential that any and all service work that may be required on your Mitsubishi brand UPS equipment is performed by a Mitsubishi Electric Authorized Service Center. The use of non-authorized service providers may void your warranty.

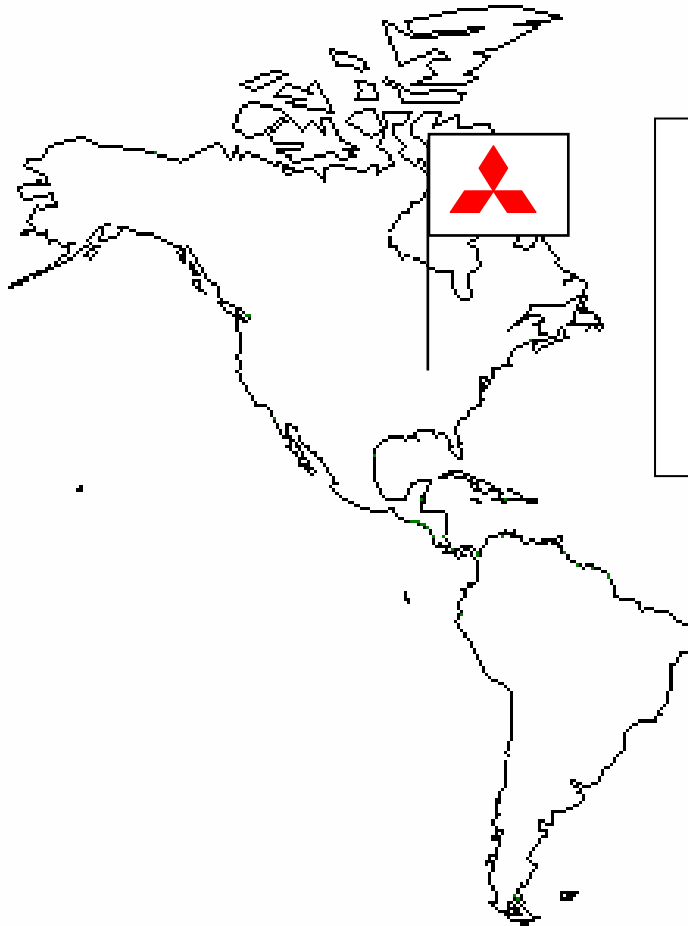

Mitsubishi Electric Automation Inc,
UPS Systems Group Service Department

500 Corporate Woods Parkway,
Vernon Hills, Illinois 60061, USA

Phone: (847) 478-2500

Fax: (847) 478-2290

MITSUBISHI ELECTRIC
Mitsubishi Electric Automation, Inc.
UNINTERRUPTIBLE POWER SUPPLIES

500 Corporate Woods Parkway, Vernon Hills, IL 60061 Phone: (847) 478-2643, Fax: (847) 478-2290

UPS Warranty Registration

 Register UPS for Warranty

 Address Change

To validate the Warranty on your UPS this form must be filled out completely by Customer and returned.

CUSTOMER INFORMATION		
Your Name:	Job Title:	
Company Name:		
Division / Department:		
Address:		
City:	State:	Zip Code:
Country:	Province:	
Business Phone:	Ext:	Fax:
E-Mail: _____ @ _____	Internet Address:	
UPS Model #:	Capacity (kVA):	UPS Serial #:
Start-Up Date: / /	Authorized Mitsubishi Service Company (if known):	
Signature: _____	Date: / /	

Which ONE of These Best Describes Your Organization's Primary Business Classification?
Number of Employees at This Location is:
 {Energy Producer}
 Utility
 Alternate Energy

 Education/Univ. Service
{Service}
 Consulting

 {Manufacturing Co.}
 OEM

 Process

 Engineering

 Outsourcing

 Financial/Legal/Insurance

{Expectations}
 Consumer Goods

 Electronics

 Power Quality Equipment

 Commercial Business
 Electrical Contractor
 Healthcare
 Internet
{Government}
 Military

 Municipals

 Federal/State/Local

 Communications
 Distributors/Reps
 Other _____

 1 - 19 100 - 249 1000 or more

 20 - 49 250 - 499

 50 - 99 500 - 999

Overall how was Start-Up performed:
 Unsatisfactory Satisfactory Exceeded

Would you like to receive future product updates and news?
 Yes No

**After Start-Up has been done Fax completed Form to:
(847) 478-2290**